



BUILT-IN CHARGING AND AUDIO STATION

Charge your tablet or smart-phone inside the sauna and connect your favorite audio device with Bluetooth or the included MP3 jack.

BUILT-IN ERGONOMIC BACKREST

Relax close to the soothing infrared heat against the Chiropractor designed built-in ergonomic backrest.

BEAUTIFUL ACCENT LIGHTS

Energy efficient LED lights highlight the beauty of your sauna while providing gentle ambient lighting.

COMBINATION DOOR HANDLE/TABLET CRADLE FOR EASY MEDIA VIEWING

Place your tablet on the door handle for easy viewing of your favorite shows or movies.

ITALIAN INSPIRED DESIGN AND GLASS ROOF

The open feel and beautiful design of your Sanctuary sauna will compliment every room.

THERAPEUTIC FAR INFRARED HEATERS

Our exclusive TrueWave® combination carbon/ceramic low EMF / low ELF heaters surround you in healing infrared heat.

TRUE WAVE® FULL SPECTRUM HEATERS

Our full spectrum near, mid and far infrared heaters deliver over 20 times the power of the nearest leading competitor. Our patented heating system allows for the deepest penetration with peak performance for the best results.

DOCTOR DESIGNED ERGONOMIC BENCH

Relax in comfort with our reversible bench. The extra deep bench is ergonomic on one side and flat on the other for maximum comfort. The bench can be flipped at any time.

ENHANCED AUDIO SOUND SYSTEM



Bluetooth and AUX inputs makes it easy to connect and listen to your audio devices.

DIGITAL KEYPAD CONTROLS



Never Fail™ digital keypad controls temperature, time, lights, heater intensity and reservation mode.

COLOR LIGHT THERAPY



Your Sanctuary sauna comes standard with our healing Chromotherapy. Choose from one of twelve colors or auto-cycle through all color tones.

TABLET / SMARTPHONE CONTROL (optional)



Log in from your Android tablet or smartphone and remotely operate your sauna.

SPECIFICATIONS

Construction

Eco-Certified wood choices:
1. Mahogany Exterior/Interior
2. Basswood Exterior/Interior
Tongue & Groove Construction
Weight: 640 lbs

Exterior

Back Walls: 71"
Side Walls: 38"
Front Wall: 47"
Height: 77"
Door: 23 3/4" x 73 1/4"

Interior

Width: 68"
Depth: 68"
Height: 74"
Bench: 66" x 22"
Bench Height: 20"

Heaters

TrueWave® Carbon/Ceramic
Far infrared and full spectrum heaters
Power: 240V / 3,220W / 13.5A

Limited Lifetime Residential Warranty

Cabinetry & Glass
Electrical
Heaters
Controls

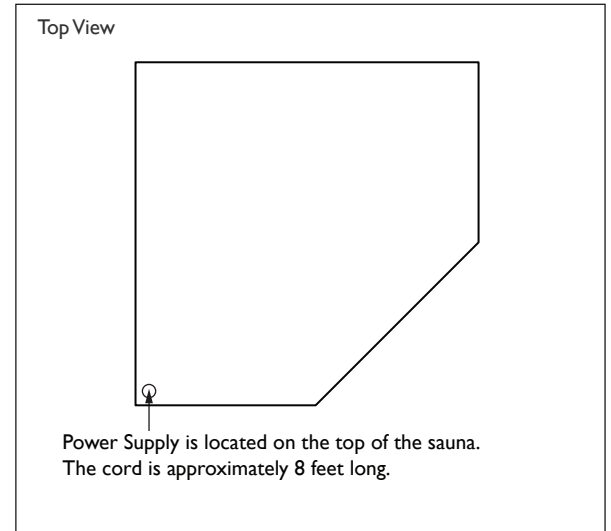
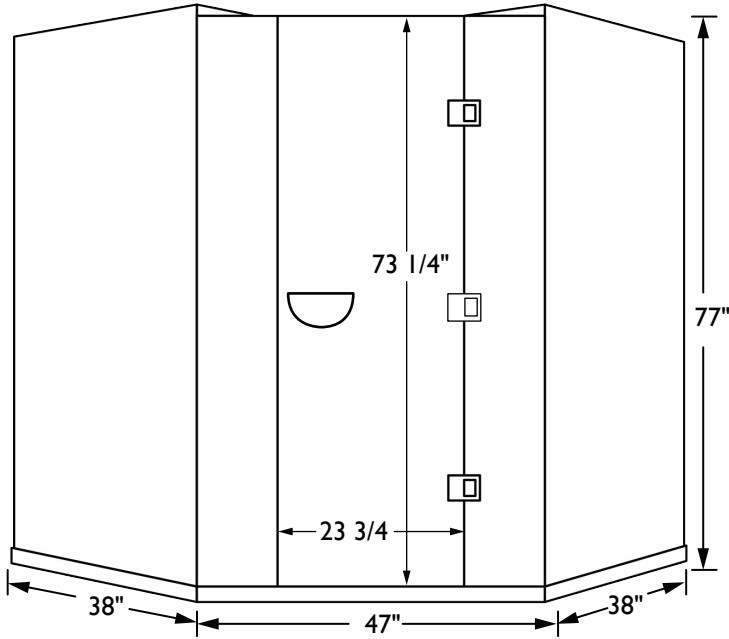

Top View

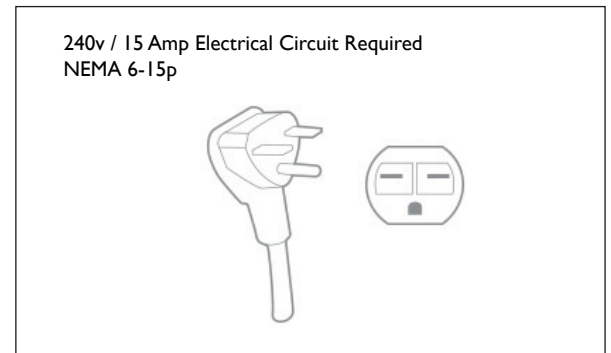
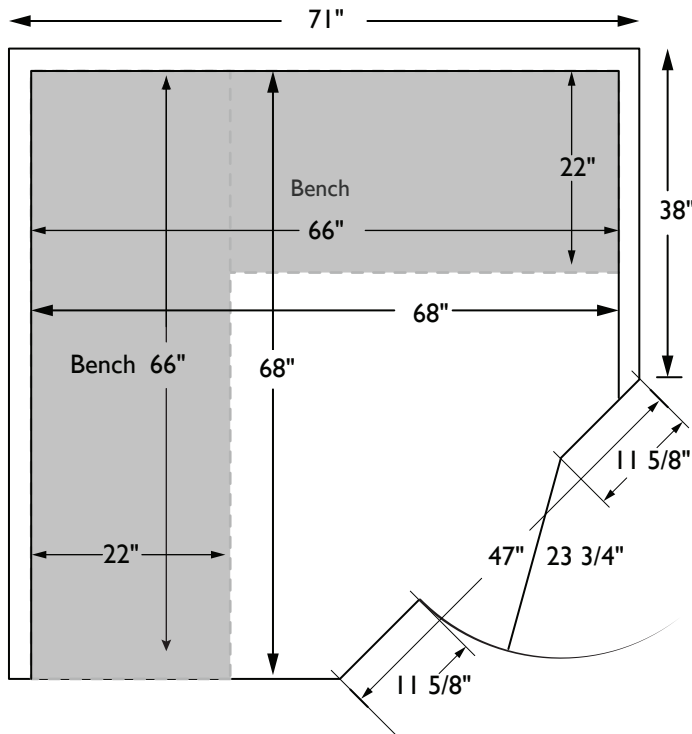

SPECIFICATIONS

Construction

Eco-Certified wood choices:
1. Mahogany Exterior/Interior
2. Basswood Exterior/Interior
Tongue & Groove Construction
Weight: 640 lbs

Exterior

Back Walls: 71"
Side Walls: 38"
Front Wall: 47"
Height: 77"
Door: 23 3/4" x 73 1/4"

Interior

Width: 68"
Depth: 68"
Height: 74"
Bench: 66" x 22"
Bench Height: 20"

Heaters

TrueWave® Carbon/Ceramic
Far infrared and full spectrum heaters
Power: 240V / 3,220W / 13.5A

Limited Lifetime Residential Warranty

Cabinetry & Glass
Electrical
Heaters
Controls